

OPERATING INSTRUCTIONS

AT3391 OIL FILTER CUTTER CHANGING THE WHEEL CUTTER HEIGHT

INTRODUCTION

This instruction provides the necessary information for converting the wheel height on the oil filter cutter. The oil filter cutter is typically shipped with the cutting wheel positioned at a 0.5" (12.7mm) cutting height. The cutting wheel can be positioned to a 0.75" (19mm) cutting height by following the changing procedure below.

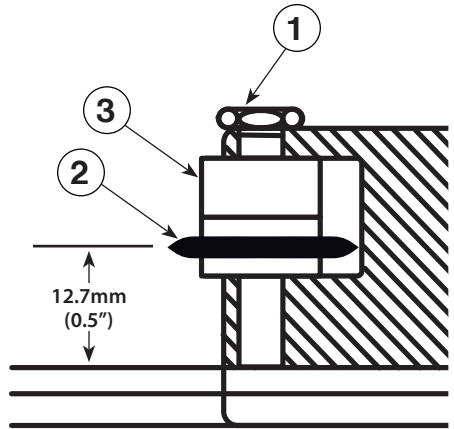

CHANGING PROCEDURE

1. Remove hex head shoulder bolt (1).
2. Switch the cutter wheel (2) with the height spacer (3).
3. Install hex head shoulder bolt (1) and retighten.

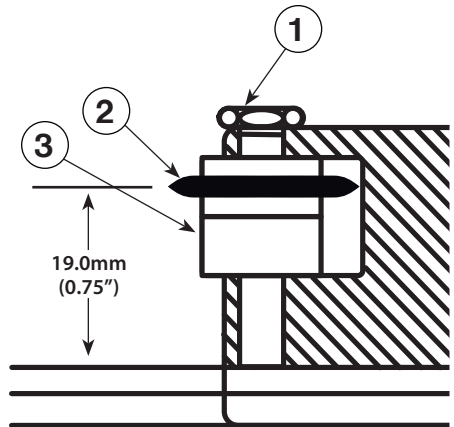

Call K-Line Customer Service at
1-800-824-K-LINE (5546) or FAX 1-800-528-9138
www.klineind.com or Email: cservice@klineind.com

K-Line[®]
INDUSTRIES

315 Garden Avenue • Holland, MI 49424 • Ph: (616) 396-3564 • Fax: (616) 396-8974



P/N 44 3391-200 Rev 2/11