

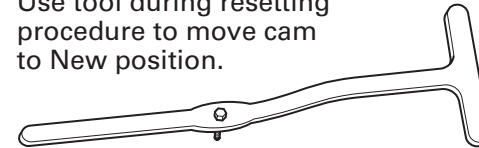

# Eaton® Solo Advantage™ Clutch Reset Tool 15" Solo Advantage™ Heavy Duty Clutch

**Roadranger®** More time on the road®

Use tool during resetting procedure to move cam to New position.



**Tool Part Code:**  
CLPI-SOLOTOOL

- 1** Measure distance between release bearing and clutch brake.

If measurement is not between 0.490" and 0.560", reset clutch. Go to step 2.

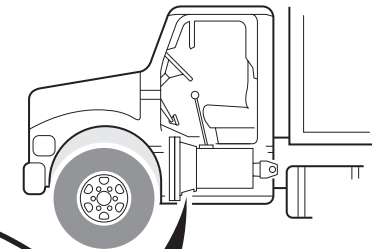

**Correct distance =  
0.490" - 0.560"**

**Release Bearing**

**Clutch Brake**

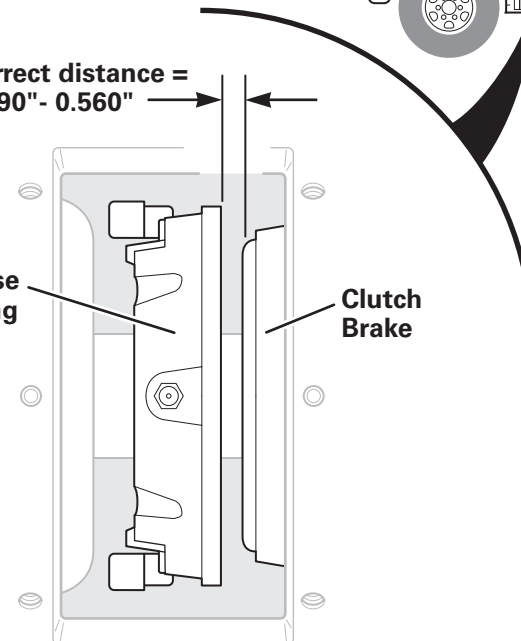

EATON AND DANA hereby grants its customers, vendors, or distributors permission to freely copy, reproduce and/or distribute this document in printed format. It may be copied only in its entirety without any changes or modifications. THIS INFORMATION IS NOT INTENDED FOR SALE OR RESALE, AND THIS NOTICE MUST REMAIN ON ALL COPIES.



National Institute for  
**AUTOMOTIVE  
SERVICE  
EXCELLENCE**

**Roadranger®**



For spec'ing or service assistance, call 1-800-826-HELP (4357) 24 hours a day, 7 days a week (Mexico:001-800-826-4357), for more time on the road. Or visit our website at [www.roadranger.com](http://www.roadranger.com).

Roadranger: Eaton, Dana and other trusted partners providing the best products and services in the industry, ensuring more time on the road.

Eaton Corporation • Truck Components Operations • P.O. Box 4013  
Kalamazoo, MI 49003 • U.S.A. • [www.roadranger.com](http://www.roadranger.com)

©2008 Eaton Corporation - All rights reserved.  
Printed in USA

**CLMT1307  
October 2010**

- 2** Have assistant hold clutch pedal down.

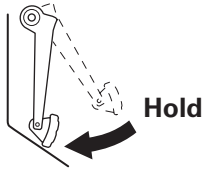

- 3** Position tool:
- Through access panel
  - Under release bearing
  - Threaded bolt in cam slot

- 4** Use tool to move cam to New position.



**Note:** If cam does not move, loosen transmission and install 1/2" spacers between clutch housing and engine housing to increase stroke.

With spacers in place:

- Have assistant hold clutch pedal down
- Use tool to move cam to New position
- Release clutch pedal

Remove spacers and torque transmission mounting bolts.

- 5** Release clutch pedal.

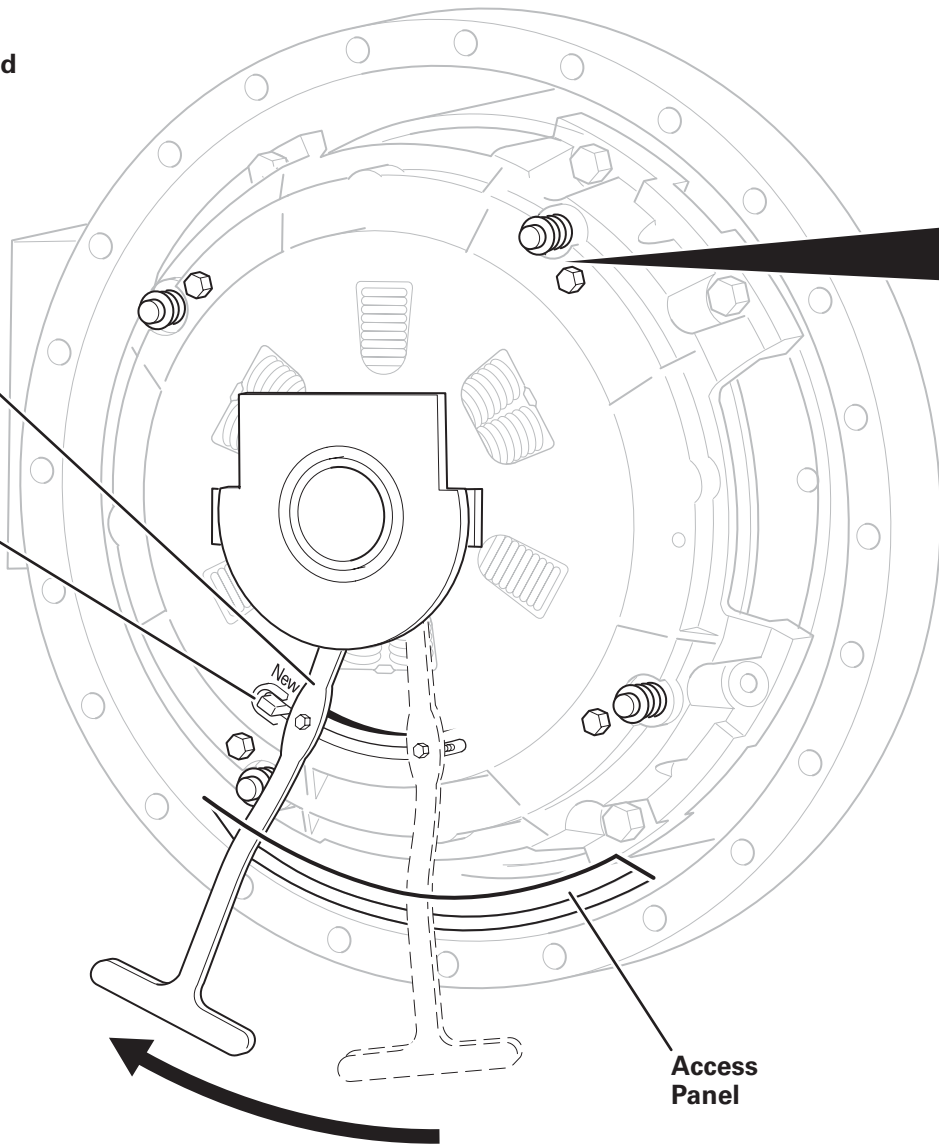
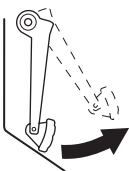

- 6** Install and tighten 4 shipping bolts (7/16" x 14 x 1-3/4 UNC) to remove gap between sleeve and pin.

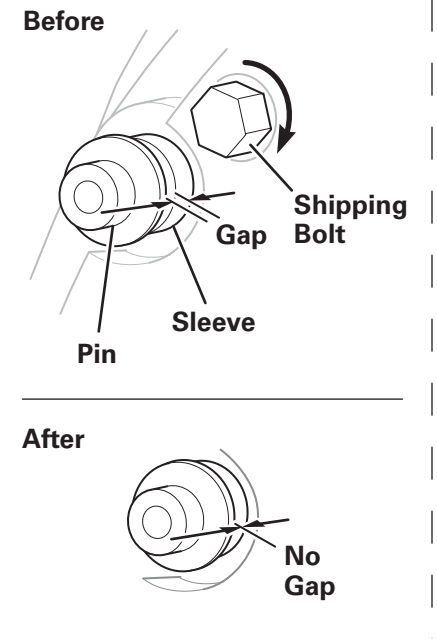

- 7** Remove 4 shipping bolts.

- 8** Push pedal down and squeeze clutch brake 5 times to reposition bearing.

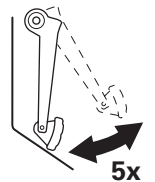

- 9** Verify reset. Go to step 1.